

# COOLING SYSTEM 2.0

## CONTENTS

### Description and Operation

	Page
Cooling system components - naturally aspirated .....	2
Cooling system components - turbo .....	3
Cooling system flow diagram - naturally aspirated .....	4
Cooling system flow diagram - turbo .....	5

---

### Adjustments

	Page
Drain and refill .....	1

---

### Repairs

	Page
Thermostat and housing .....	1
Thermostatic switch .....	2
Cooling fan assembly - naturally aspirated .....	3
Radiator - naturally aspirated .....	5
Water pump .....	6
Water pump housing .....	7
Cooling fan assembly - turbo .....	11
Radiator and intercooler - turbo .....	12

---





# COOLING 2.0

## DESCRIPTION AND OPERATION

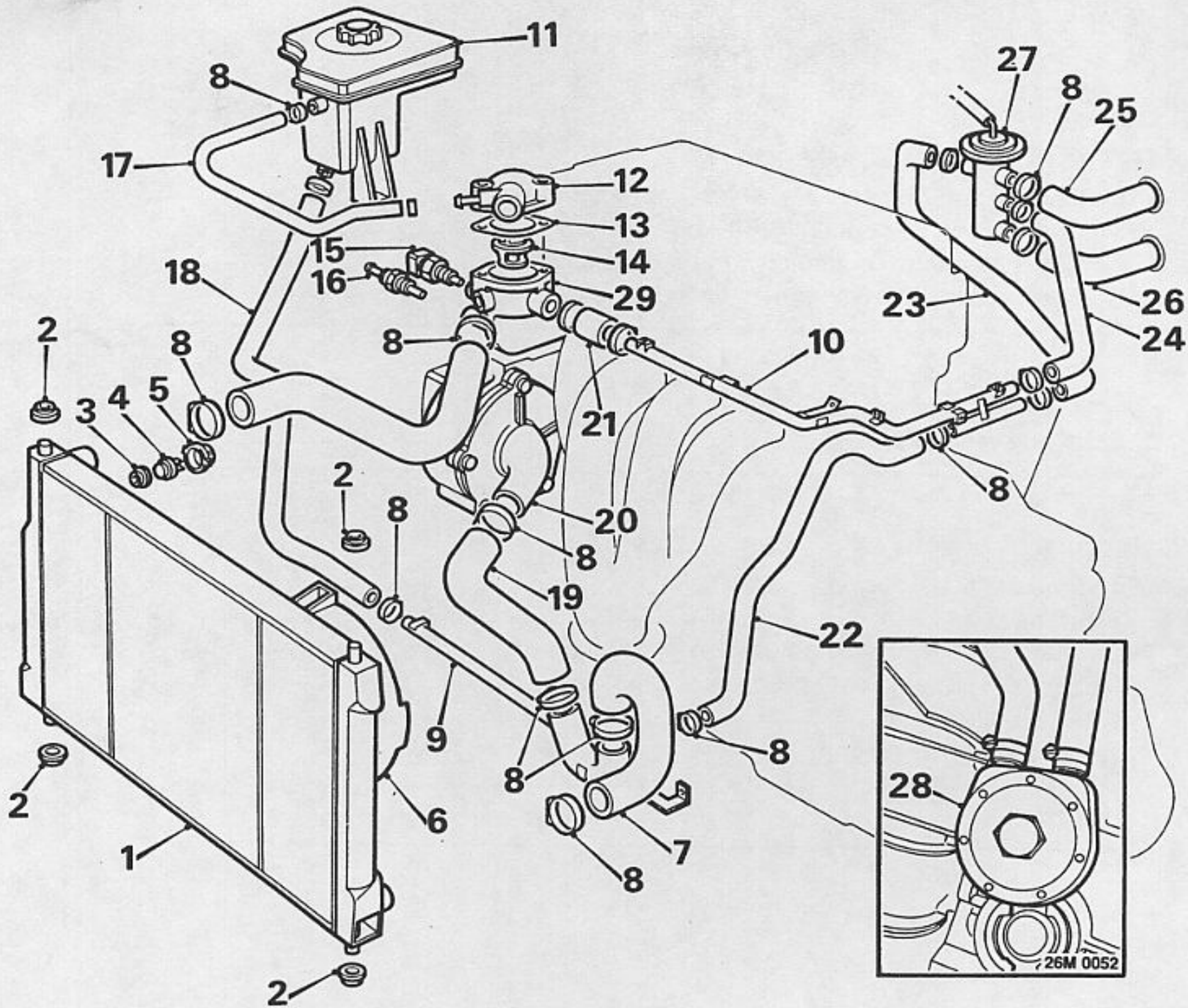

### COOLING SYSTEM COMPONENTS - NATURALLY ASPIRATED

- |                                          |                                                  |
|------------------------------------------|--------------------------------------------------|
| 1. Radiator                              | 16. Temperature sensor - Instruments             |
| 2. Mounting grommet                      | 17. Hose - expansion tank to thermostat          |
| 3. Seal                                  | 18. Hose - expansion tank to radiator rail       |
| 4. Thermostatic switch                   | 19. Hose - water pump to radiator rail           |
| 5. Retainer - bayonet fixing             | 20. Water pump                                   |
| 6. Cooling fan, motor and cowl           | 21. Hose - thermostat to heater rail assembly    |
| 7. Bottom hose - radiator                | 22. Hose - radiator rail to heater rail assembly |
| 8. Hose clips                            | 23. Hose - heater rail assembly to water valve   |
| 9. Radiator rail                         | 24. Hose - water valve to heater rail assembly   |
| 10. Heater rail assembly                 | 25. Hose - water valve to heater                 |
| 11. Expansion tank                       | 26. Hose - heater to water valve                 |
| 12. Coolant outlet elbow                 | 27. Water valve                                  |
| 13. Thermostat gasket                    | 28. Modine oil cooler - automatic only           |
| 14. Thermostat                           | 29. Thermostat housing                           |
| 15. Temperature sensor - M.E.M.S. E.C.U. |                                                  |

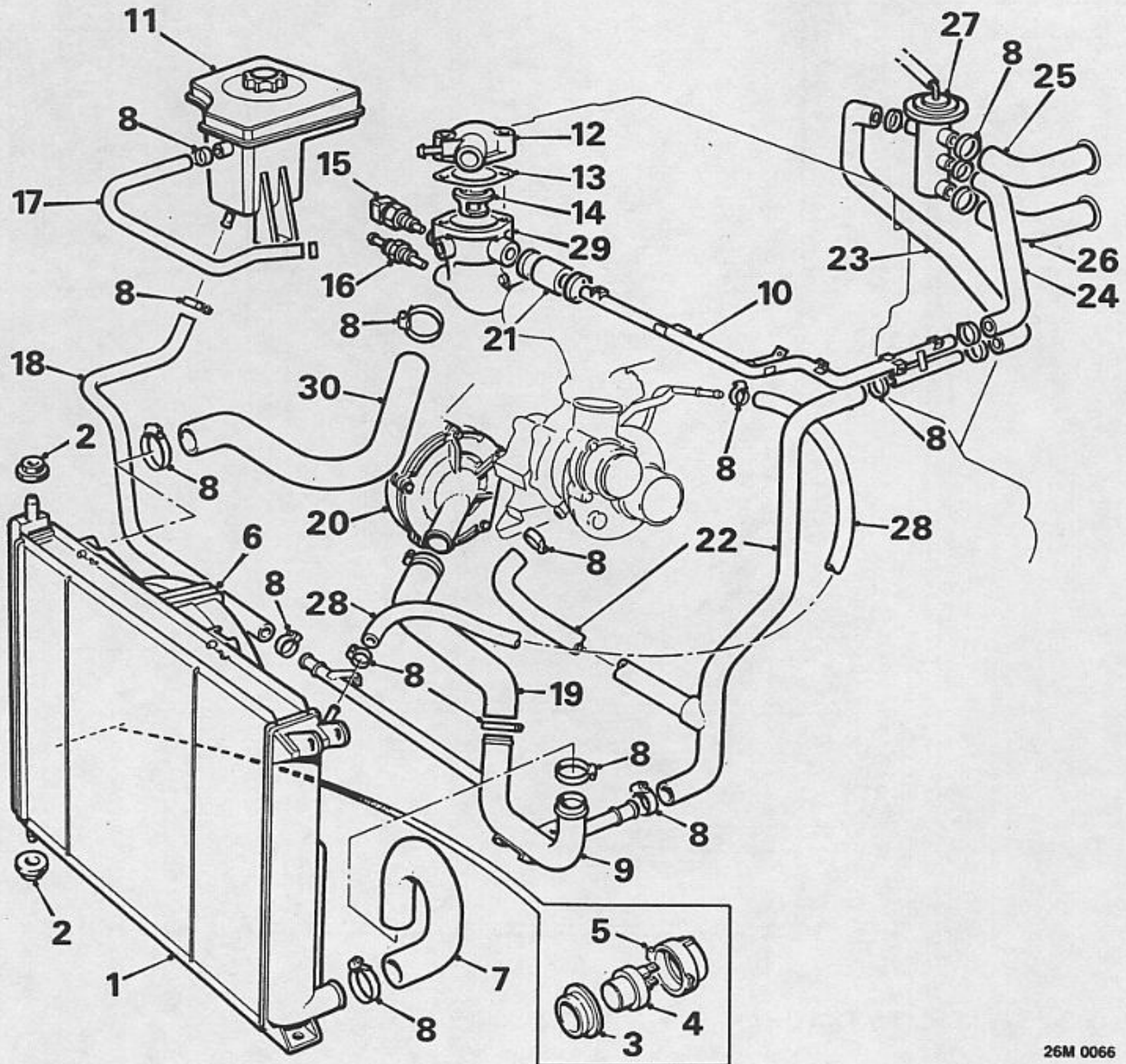

26M 0066

**COOLING SYSTEM COMPONENTS - TURBO**

- |                                                                                                                                                                                                                                                                                                                                                                                                                                                                                                                                                                      |                                                                                                                                                                                                                                                                                                                                                                                                                                                                                                                                                                                                                                                                                                              |
|----------------------------------------------------------------------------------------------------------------------------------------------------------------------------------------------------------------------------------------------------------------------------------------------------------------------------------------------------------------------------------------------------------------------------------------------------------------------------------------------------------------------------------------------------------------------|--------------------------------------------------------------------------------------------------------------------------------------------------------------------------------------------------------------------------------------------------------------------------------------------------------------------------------------------------------------------------------------------------------------------------------------------------------------------------------------------------------------------------------------------------------------------------------------------------------------------------------------------------------------------------------------------------------------|
| <ul style="list-style-type: none"> <li>1. Radiator</li> <li>2. Mounting grommet</li> <li>3. Seal</li> <li>4. Thermostatic switch</li> <li>5. Retainer - bayonet fixing</li> <li>6. Cooling fan, motor and cowl</li> <li>7. Bottom hose - radiator</li> <li>8. Hose clips</li> <li>9. Radiator rail</li> <li>10. Heater rail assembly</li> <li>11. Expansion tank</li> <li>12. Coolant outlet elbow</li> <li>13. Thermostat gasket</li> <li>14. Thermostat</li> <li>15. Temperature sensor - M.E.M.S. E.C.U.</li> <li>16. Temperature sensor - Instruments</li> </ul> | <ul style="list-style-type: none"> <li>17. Hose - expansion tank to thermostat</li> <li>18. Hose - expansion tank to radiator rail</li> <li>19. Hose - water pump to radiator rail</li> <li>20. Water pump</li> <li>21. Hose - thermostat to heater rail assembly</li> <li>22. Hose - radiator rail to heater rail and turbocharger assembly</li> <li>23. Hose - heater rail assembly to water valve</li> <li>24. Hose - water valve to heater rail assembly</li> <li>25. Hose - water valve to heater</li> <li>26. Hose - heater to water valve</li> <li>27. Water valve</li> <li>28. Hose - turbocharger to radiator</li> <li>29. Thermostat housing</li> <li>30. Hose - thermostat to radiator</li> </ul> |
|----------------------------------------------------------------------------------------------------------------------------------------------------------------------------------------------------------------------------------------------------------------------------------------------------------------------------------------------------------------------------------------------------------------------------------------------------------------------------------------------------------------------------------------------------------------------|--------------------------------------------------------------------------------------------------------------------------------------------------------------------------------------------------------------------------------------------------------------------------------------------------------------------------------------------------------------------------------------------------------------------------------------------------------------------------------------------------------------------------------------------------------------------------------------------------------------------------------------------------------------------------------------------------------------|



# COOLING 2.0

## DESCRIPTION AND OPERATION

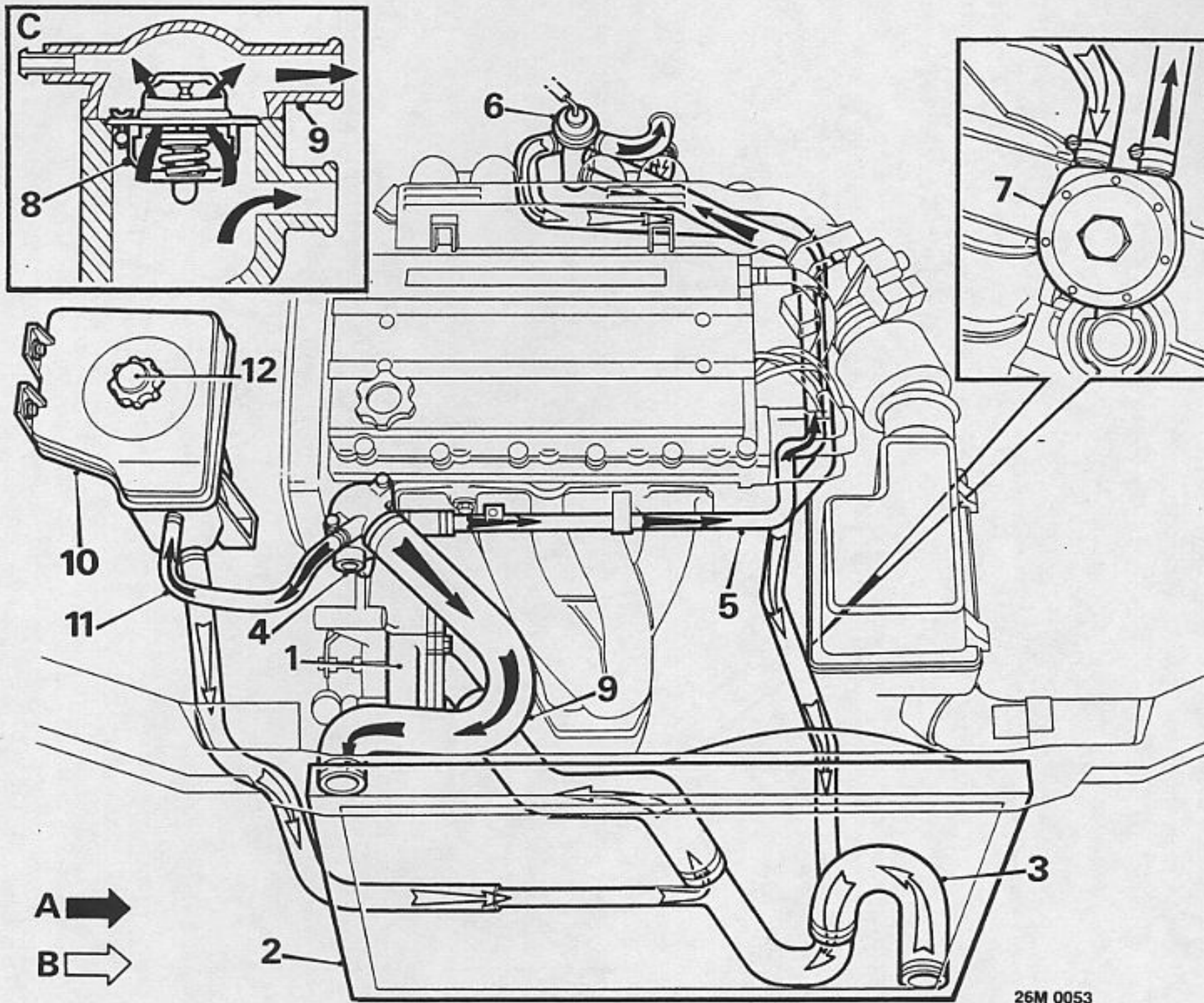

### COOLING SYSTEM FLOW DIAGRAM - NATURALLY ASPIRATED

A. Hot

B. Cold

C. Thermostat open

The centrifugal type water pump (1) is driven directly off the back of the power steering pump. Coolant is drawn from the radiator (2) via the bottom hose (3), is circulated through the water pump to the cylinder block and rises through the cylinder head to the thermostat housing (4).

Until operating temperature is reached coolant flow is restricted by the closed wax - type thermostat. Coolant for the heater bypasses the thermostat housing via the heater rail assembly (5) to the water valve (6).

**Naturally aspirated:** Coolant is returned to the bottom hose via the heater matrix (dependent on the position of the heater temperature control). When an automatic gearbox is fitted, coolant returning to the bottom hose passes through a Modine oil cooler (7) on the automatic gearbox before being returned to the water pump via the bottom hose.

**Turbo:** Coolant is returned to the bottom hose via the heater matrix (dependent on the position of the heater temperature control). Coolant returning to the bottom hose breaks off and passes through the turbocharger assembly (7) before returning to the top of the radiator via a top hose.

When operating temperature is reached, the thermostat (8) opens and the coolant now flows through the top hose (9) to the radiator.

Inside the radiator, coolant passes from the top of the R.H. tank to the bottom of the L.H. tank and is cooled by air passing through the matrix. The cooling fan operates when the thermostatic switch senses that the temperature of the coolant is above 88° C.

**WARNING:** When coolant is hot the system is under pressure, protect the hands and slowly remove the pressure relief cap to release pressure before disconnecting any part of the cooling system.

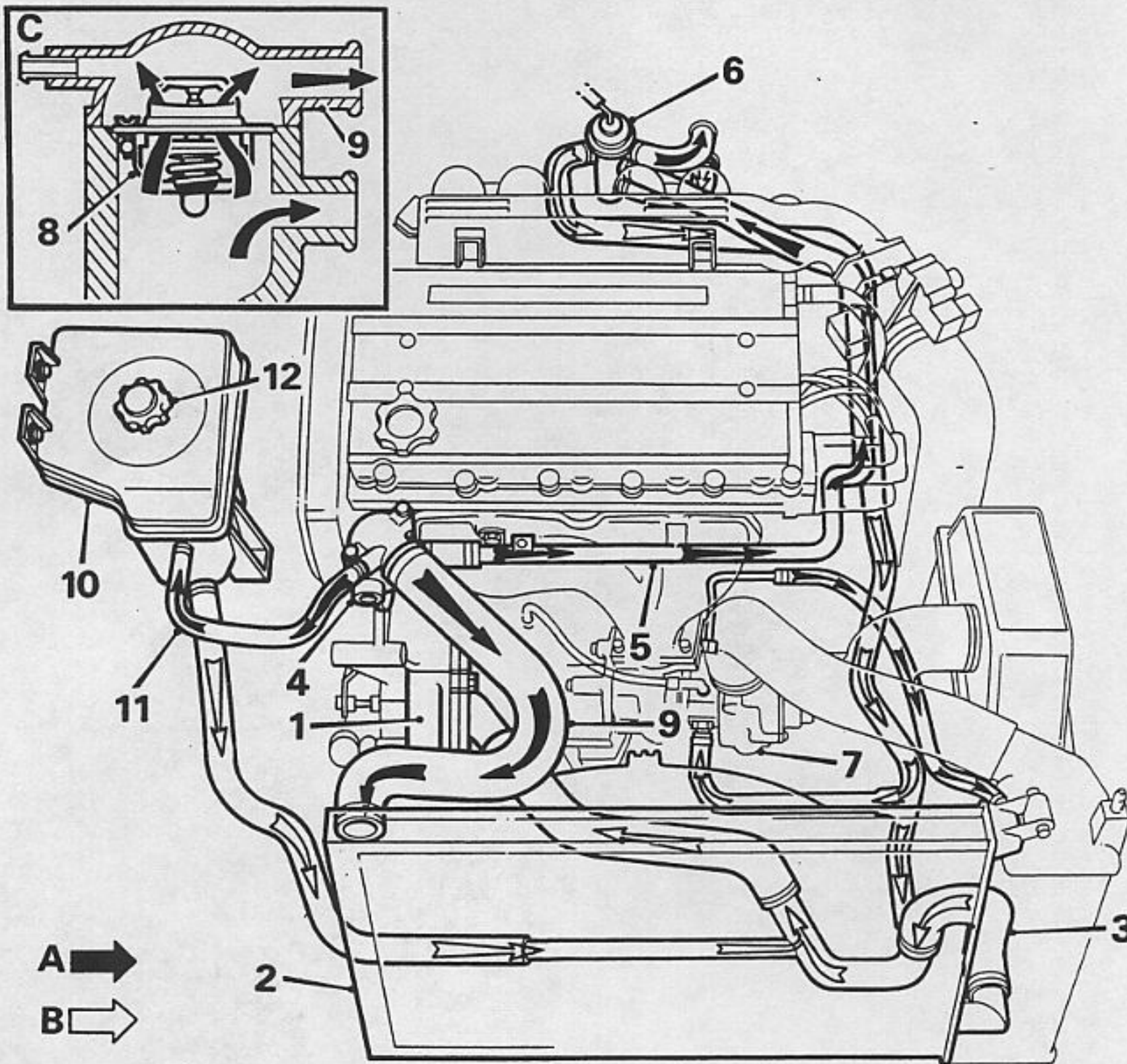

26M 0065

**COOLING SYSTEM FLOW DIAGRAM - TURBO**

**A. Hot**

**B. Cold**

**C. Thermostat open**

As coolant expands with temperature, excess is returned to the expansion tank (10) via the hose (11). The level in the expansion tank rises and the pressure increases. When pressure exceeds 1.0 bar, 15 lbf/in<sup>2</sup>, the pressure relief valve in the cap (12) opens and allows pressure to escape to atmosphere. When the engine is switched off, coolant temperature falls, pressure in the expansion tank drops and a vacuum relief valve opens in the pressure relief cap opens allowing pressure within the tank to equalise.

The coolant contains an anti-freeze mixture dependent on climatic conditions. The anti-freeze contains corrosion inhibitors, because of this under no circumstances must the system be used without anti-freeze or the correct type of corrosion inhibitor.

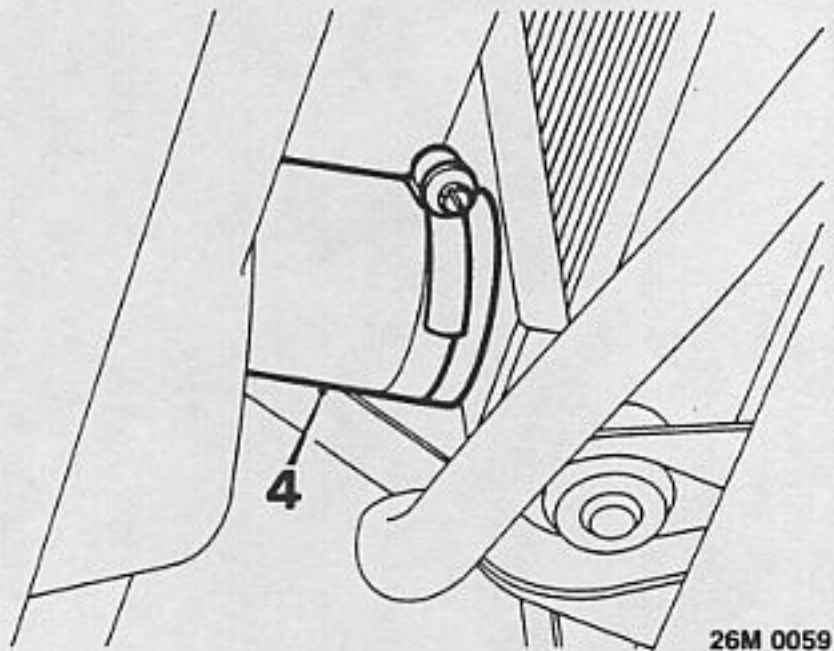
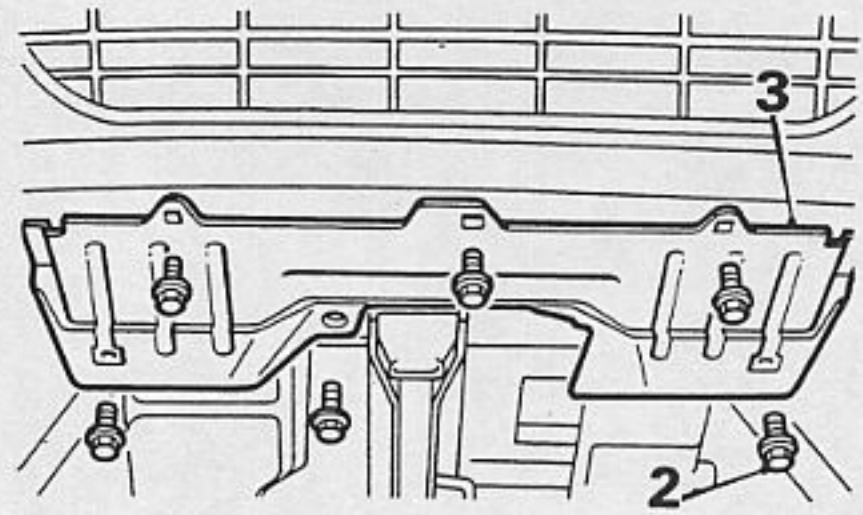
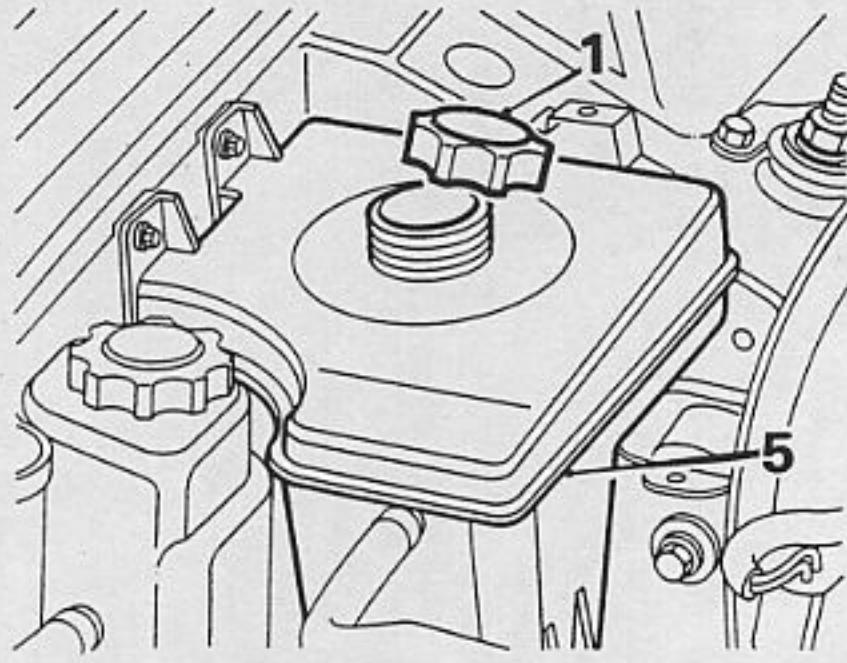

26M 0059

### DRAIN AND REFILL

**CAUTION:** Do not use radiator sealant of any kind

Action	Ref. Detail	Special Instructions
Remove	1. filler cap from reservoir	<b>WARNING:</b> System hot, protect hands against steam or boiling water, remove filler cap slowly to gradually release pressure 6 off
"	2. bolts from front under panel	
"	3. front under panel from body	
Position	3. front under panel from body	Below bottom hose
Disconnect	4. bottom hose from radiator	<b>WARNING:</b> System hot, protect hands against steam or boiling water Clean water, reverse direction through radiator using low pressure (1 bar, 15lb/in <sup>2</sup> max.) <b>CAUTION:</b> High pressure will damage the radiator
Flush	cooling system	
Connect	bottom hose to radiator	To just below filler neck
Fill	cooling system	<b>CAUTION:</b> Use correct anti-freeze mixture See <b>CAPACITIES, FLUIDS AND LUBRICANTS</b>
Fit	filler cap to reservoir	
Run	engine	Until cooling fan operates and switches off
Stop	engine	Allow to cool
Fit	front under panel to body	6 off bolts See <b>TORQUE WRENCH SETTINGS</b>
Fill	5. reservoir	To reservoir seam

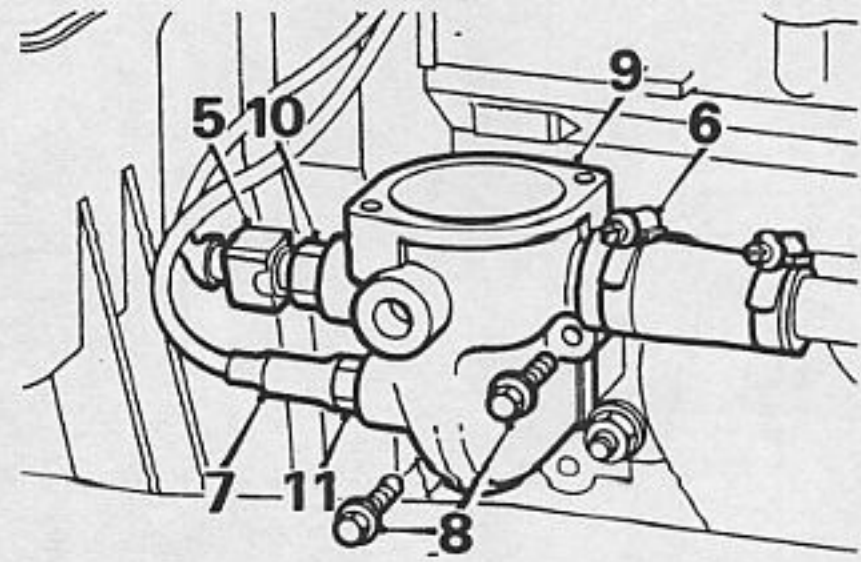
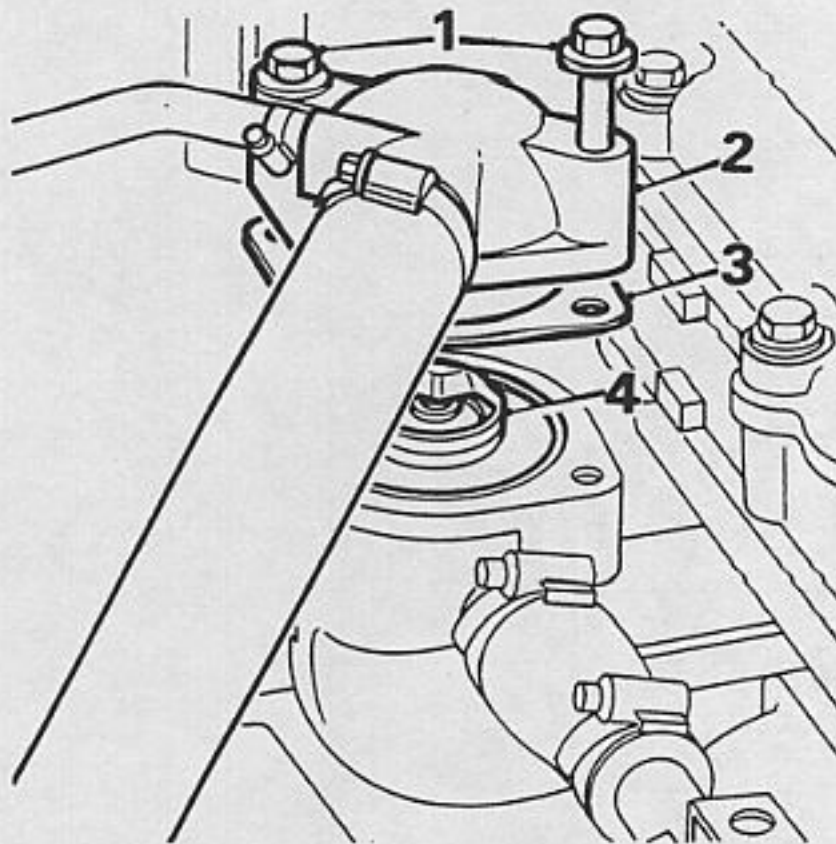

26M 0055

**THERMOSTAT AND HOUSING**

Action	Ref. Detail	Special Instructions
Remove	filler cap from expansion tank	<b>WARNING:</b> System hot, protect hands against steam or boiling water, remove filler cap slowly to gradually release pressure
Position	drain tray	Below thermostat housing
Remove	1. bolts from outlet elbow	2 off See <b>TORQUE WRENCH SETTINGS</b>
Disconnect	2. outlet elbow from gasket	
Remove	3. gasket from thermostat housing	Discard
"	4. thermostat from thermostat housing	<b>CAUTION:</b> Position support legs across heater outlet pipe when refitting
Disconnect	5. multiplug from temperature transducer	
"	6. hose from thermostat housing	
"	7. connector from temperature sensor	
"	8. bolts from thermostat housing	2 off See <b>TORQUE WRENCH SETTINGS</b>
"	9. thermostat housing from gasket	
"	gasket from cylinder head	Discard
"	10. temperature transducer from housing	See <b>TORQUE WRENCH SETTINGS</b>
"	11. temperature sensor from housing	See <b>TORQUE WRENCH SETTINGS</b>
Clean	components	
Test	thermostat	See <b>MECHANICAL FAULT FINDING MANUAL</b>
Renew	housings	If damaged
Reassemble	components	In reverse order to dismantle
Fill	cooling system	See <b>Adjustments</b>

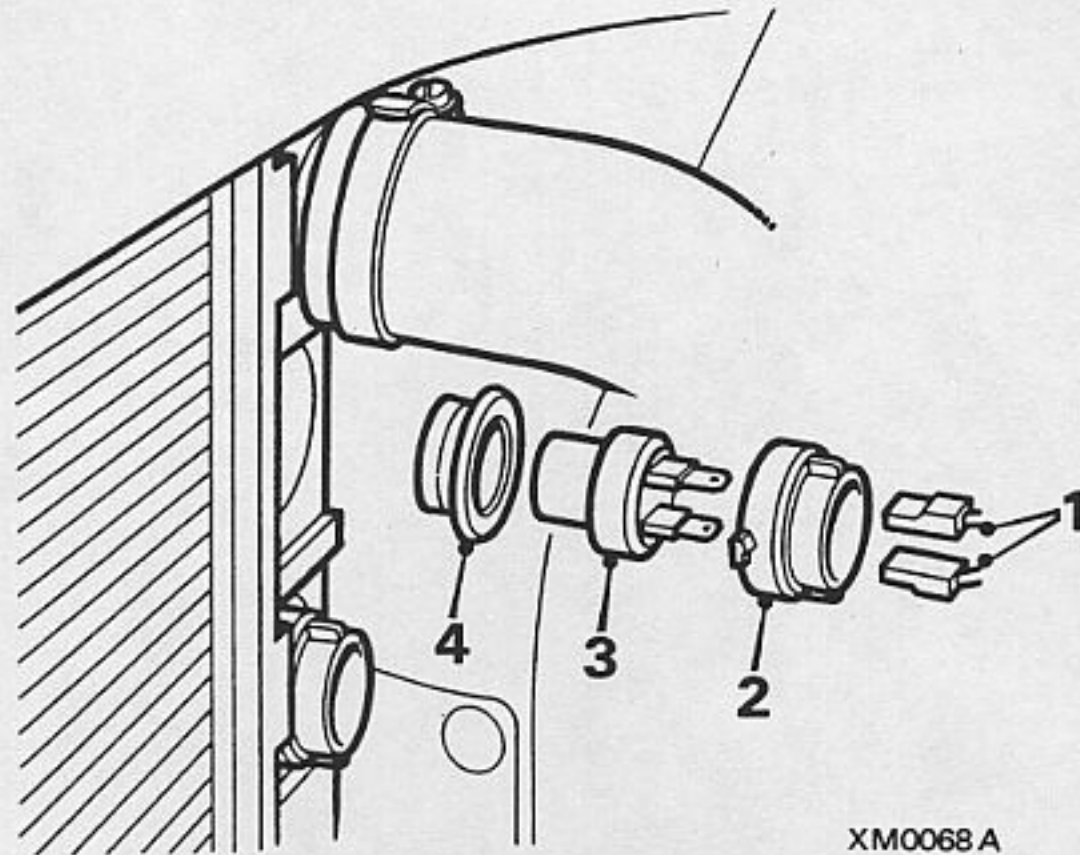

XM0068 A

### THERMOSTATIC SWITCH

Action	Ref. Detail	Special Instructions
Remove	filler cap from reservoir	<b>WARNING:</b> System hot, protect hands against steam or boiling water, remove filler cap slowly to gradually release pressure
Position	drain tray	
Disconnect	1. connectors from thermostatic switch	2 off
Remove	2. retaining ring from switch	
"	3. switch from seal	<b>WARNING:</b> System hot, protect hands against steam or boiling water
"	4. seal from radiator	Discard
Clean	components	
Reassemble	components	In reverse order to dismantle
Fill	cooling system	See <b>Adjustments</b>



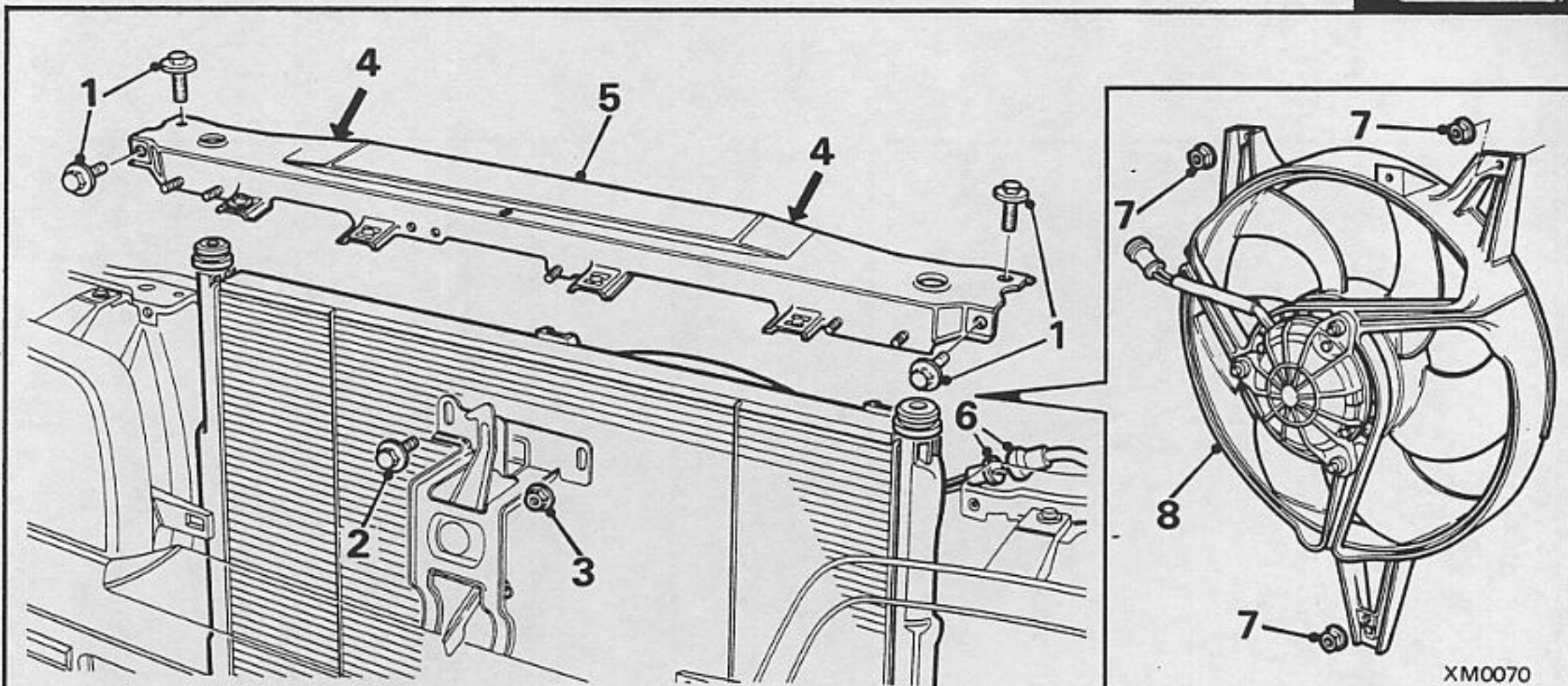

**COOLING FAN ASSEMBLY - NATURALLY ASPIRATED**

Action	Ref. Detail	Special Instructions
Remove	screws from grille	3 off
"	grille from body	
"	1. bolts from centre platform	4 off See <b>TORQUE WRENCH SETTINGS</b>
"	2. screw from safety catch	<i>Note: Earth cable</i> See <b>TORQUE WRENCH SETTINGS</b>
"	3. nut from safety catch	See <b>TORQUE WRENCH SETTINGS</b>
"	4. straps from release cable	2 off position cable in channel
"	5. bonnet platform from body	Ensure grommets correctly engaged
Disconnect	6. multiplug from fan motor	
Remove	7. nuts from fan cowl	3 off See <b>TORQUE WRENCH SETTINGS</b>
	8. fan cowl from radiator	<b>CAUTION: Fan, motor and cowl are balanced assembly, do not dismantle</b>
Clean	components	
Reassemble	components	In reverse order to dismantle



# COOLING 2.0

## REPAIRS

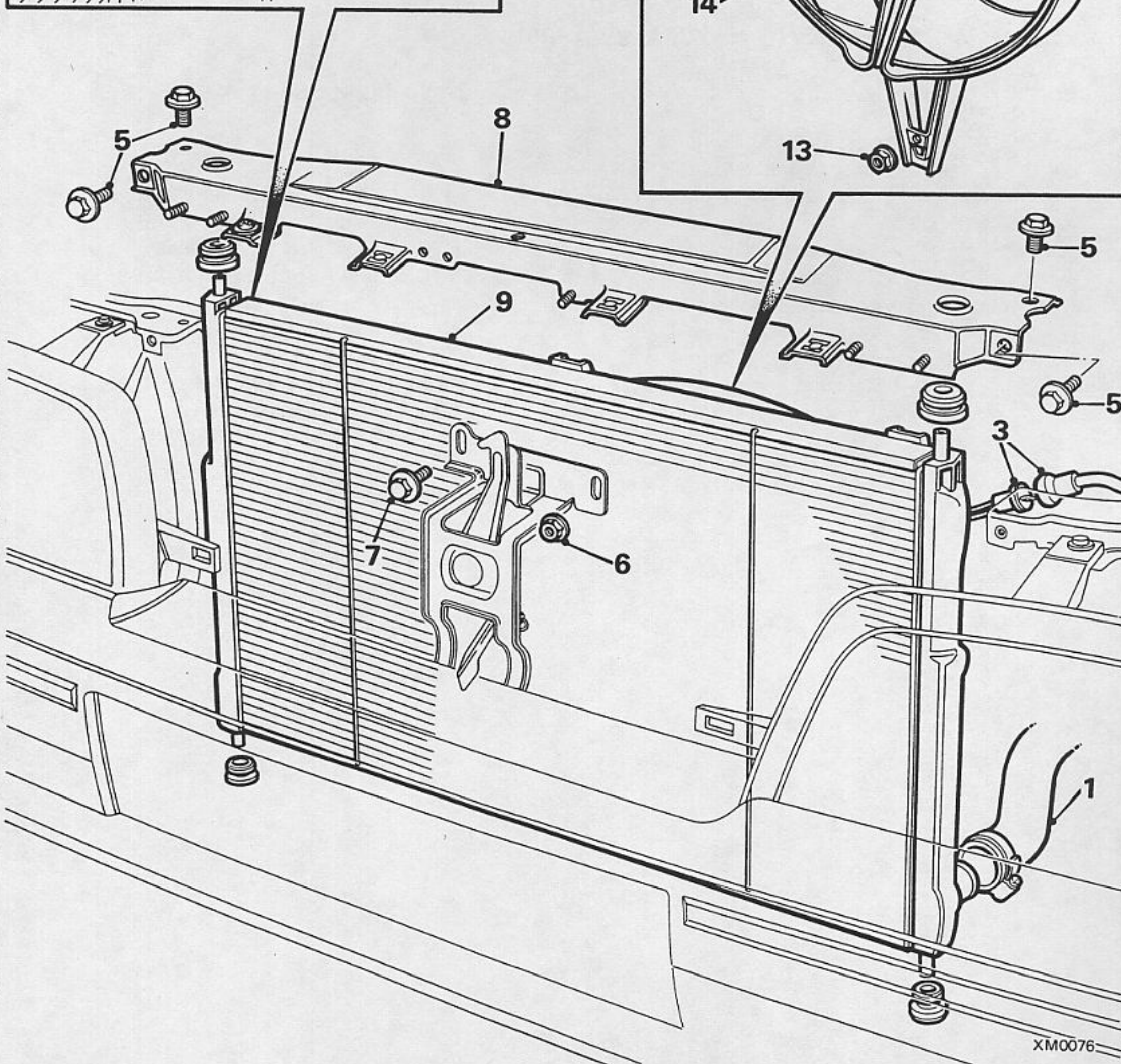
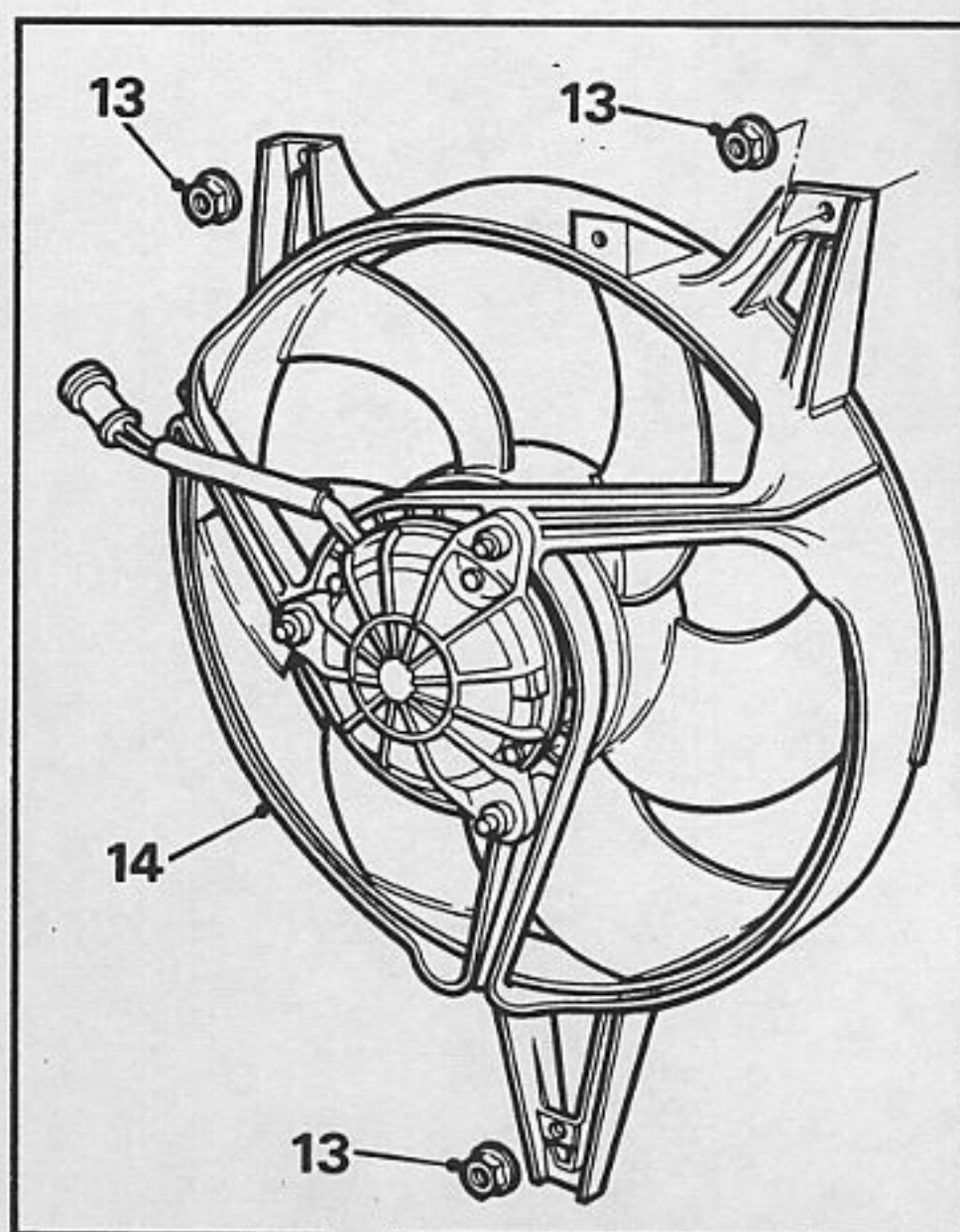
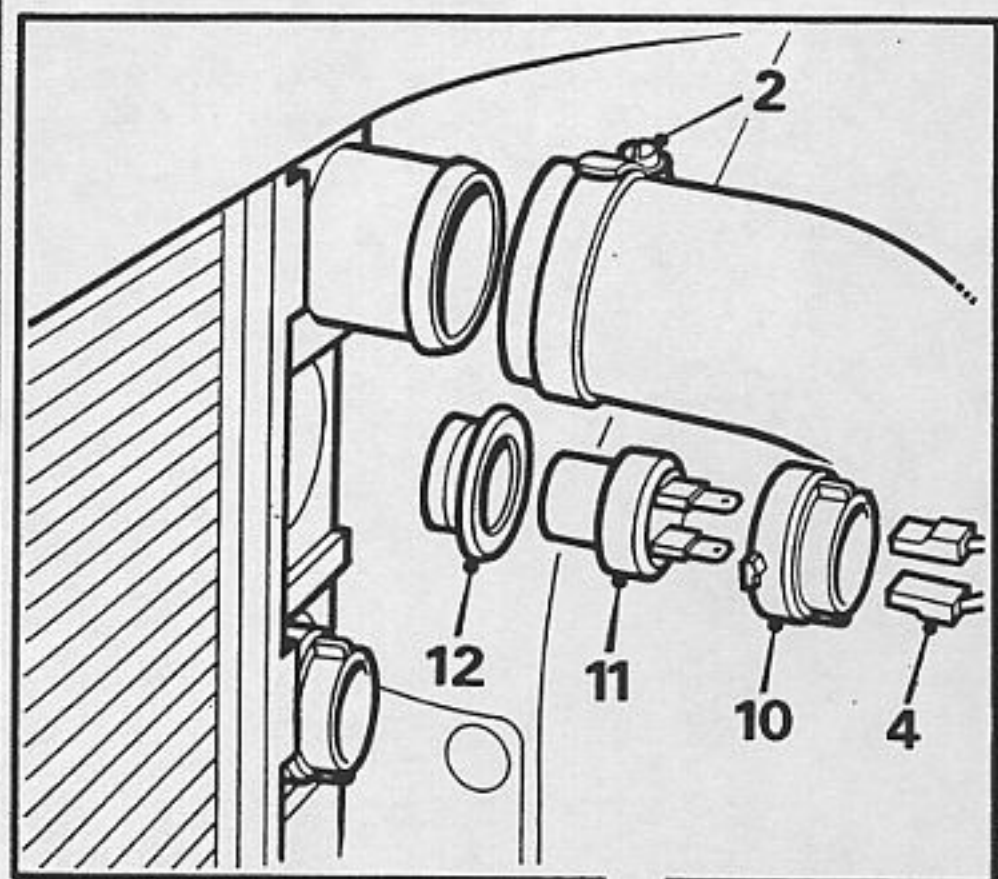

XM0076



## RADIATOR – NATURALLY ASPIRATED

Action	Ref. Detail	Special Instructions
Remove	filler cap from reservoir	<b>WARNING:</b> System hot, protect hands against steam or boiling water, remove filler cap slowly to gradually release pressure
"	bolts from front under panel	6 off See <b>TORQUE WRENCH SETTINGS</b>
"	front under panel from body	
Position	drain tray	Below radiator
Disconnect	1. bottom hose from radiator	Twist hoses to break bonding on pipe <b>CAUTION:</b> Using a lever can deform the pipe or end tank <b>WARNING:</b> System hot, protect hands against steam or boiling water
"	2. top hose from radiator	
"	3. multiplug from fan motor	
"	4. connectors from thermostatic switch	2 off
Remove	screws from grille	3 off
"	grille from body	
"	straps from release cable	2 off position cable in channel
"	5. bolts from centre platform	4 off See <b>TORQUE WRENCH SETTINGS</b> <b>Note:</b> Earth cable
"	6. nut from safety catch	See <b>TORQUE WRENCH SETTINGS</b>
"	7. screw from safety catch	See <b>TORQUE WRENCH SETTINGS</b>
"	8. centre platform from body	Ensure grommets correctly engaged
"	9. radiator from grommets	Ensure grommets correctly engaged
"	10. retaining ring from thermostatic switch	
"	11. thermostatic switch from seal	
"	12. seal from radiator	Discard
"	13. nuts from fan cowl	3 off See <b>TORQUE WRENCH SETTINGS</b>
"	14. fan cowl assembly	<b>CAUTION:</b> Fan, motor and cowl are balanced assembly do not dismantle
Clean	components	
Renew	grommets	If damaged or deteriorated
Reassemble	components	
Refill	cooling system	See <b>Adjustments</b>



# COOLING 2.0

## REPAIRS

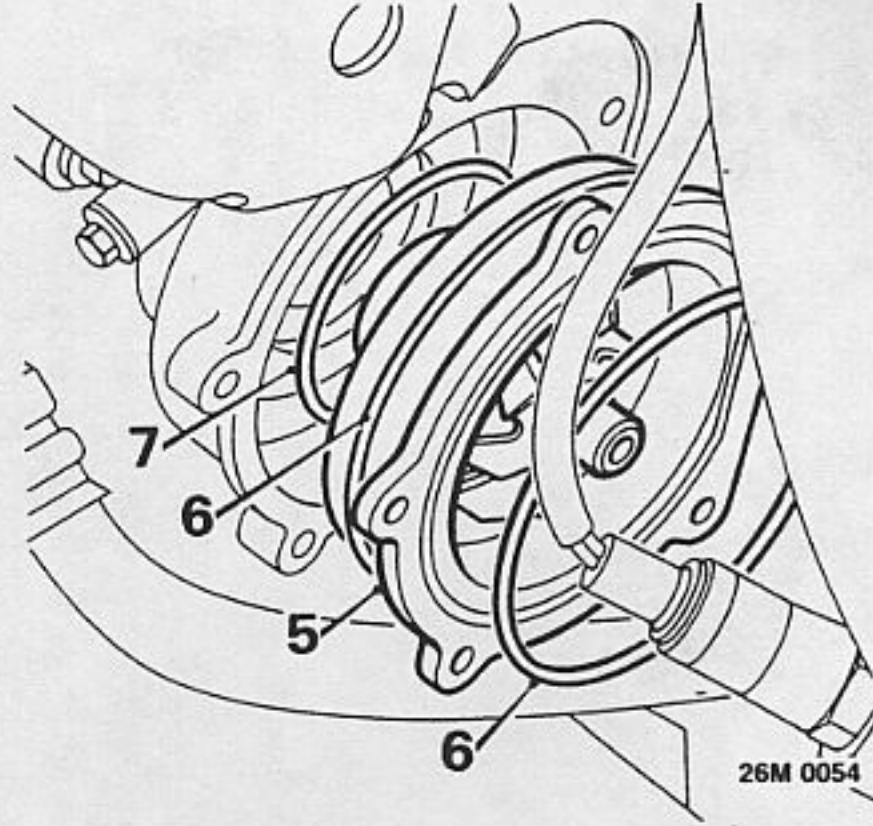
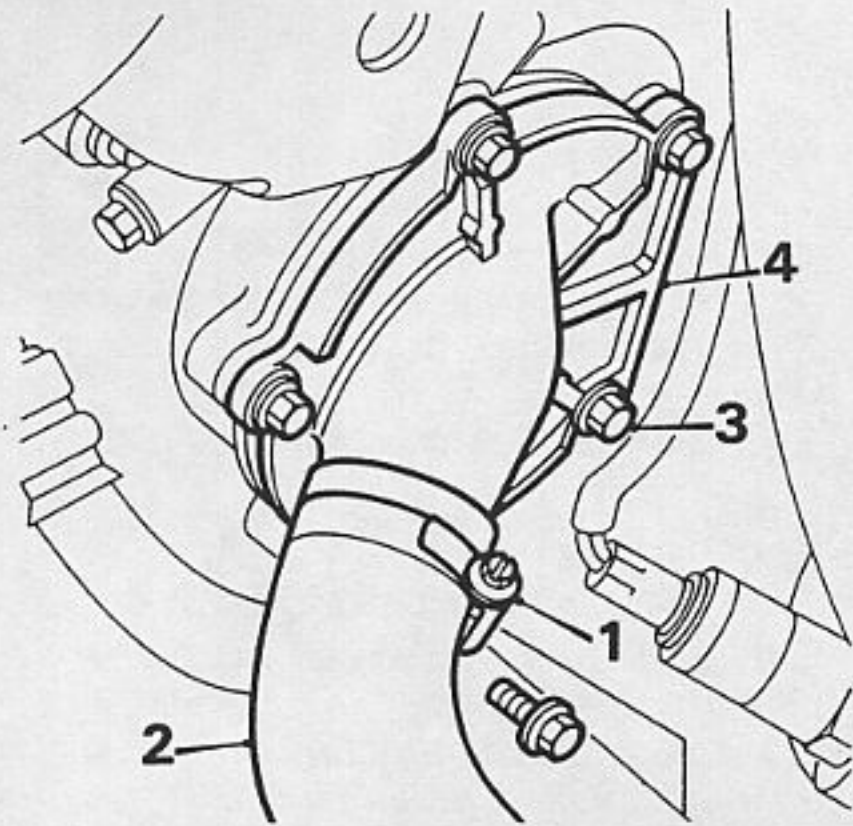

### WATER PUMP

Action	Ref. Detail	Special Instructions
Position	drain tin	Below water pump
Slacken	1. hose clip	
Disconnect	2. hose from pump housing cover	Twist hose to break bonding on pipe
Remove	3. bolts securing pump housing cover	5 off. See <b>TORQUE WRENCH SETTINGS</b>
"	4. pump housing cover	
"	5. pump from housing	
Discard	6. sealing rings	2 off
"	7. sealing ring	
Clean	pump housing and pump mating surfaces	
Apply	Loctite 405 to sealing ring grooves	
Reassemble	components	In reverse order to dismantle
Refill	cooling system	see <b>Adjustments</b>

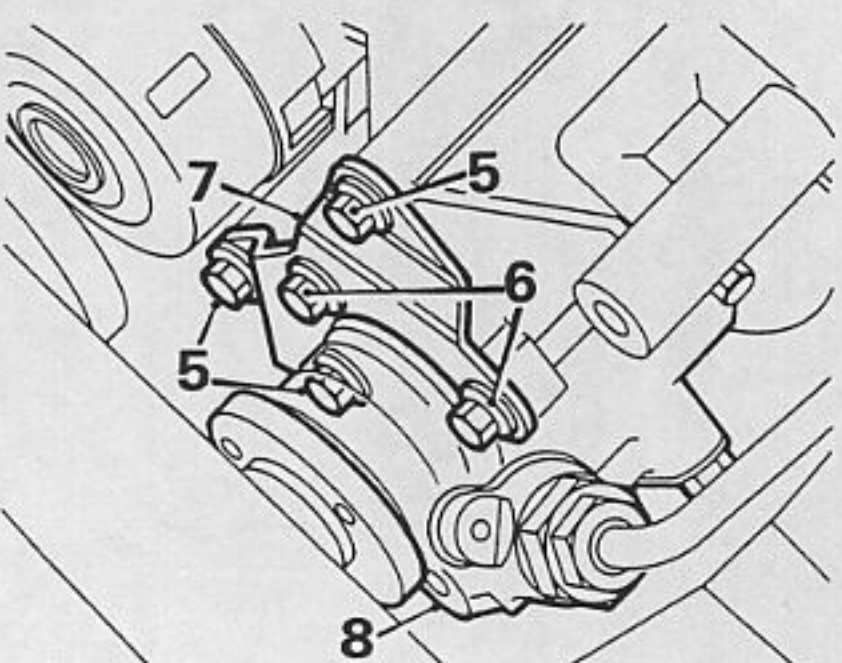
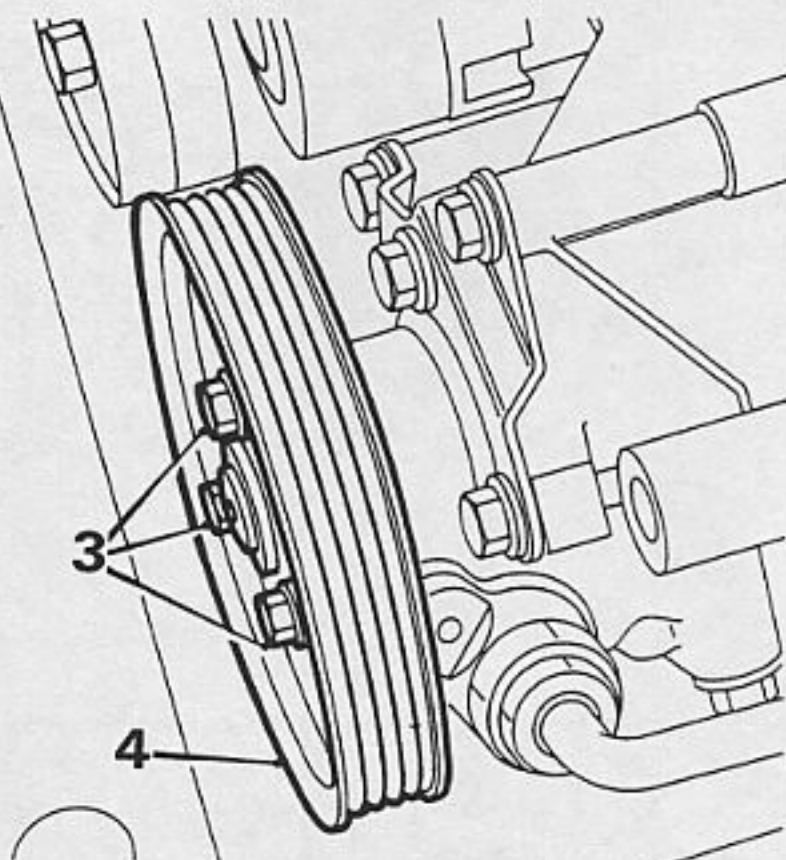
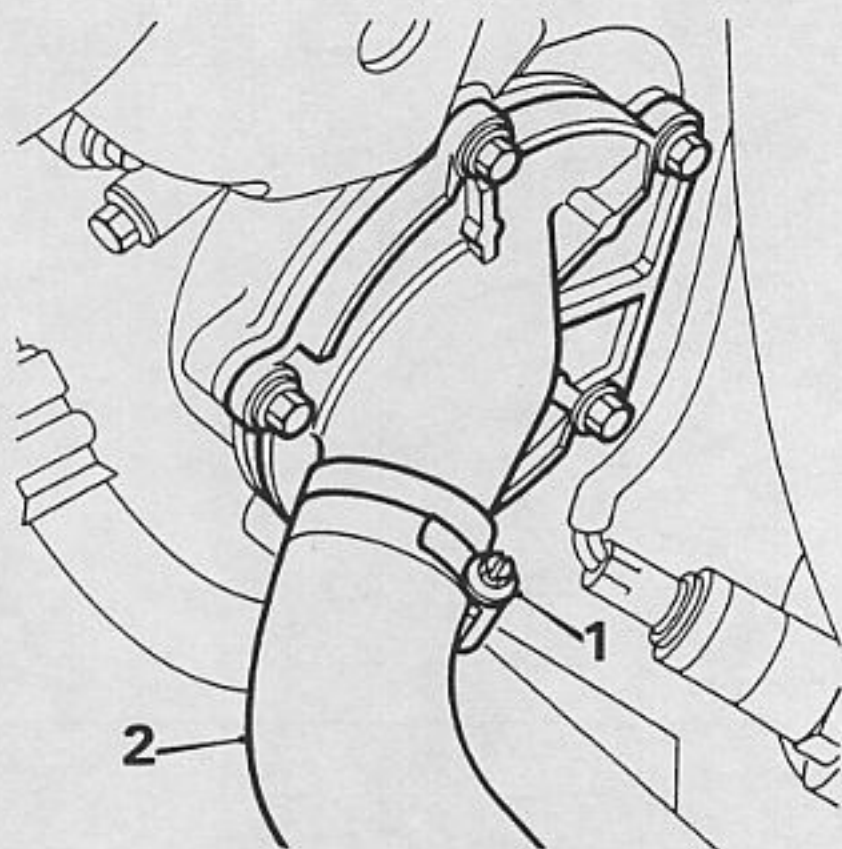
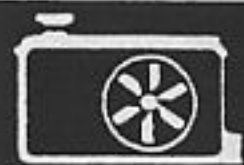

26M 0056

**WATER PUMP HOUSING**

**Action**

**Ref. Detail**

**Special Instructions**

Remove  
"

bolts from underbelly panel  
exhaust manifold

6 off. Models with air conditioning only.  
Models with air conditioning only. See  
**MANIFOLD & EXHAUST**

Remove  
Position  
Slacken

alternator  
drain tin  
1. hose clip  
2. hose from pump housing cover

See **ELECTRICAL**  
Below water pump

Disconnect  
Remove

3. bolts securing power steering pump  
pulley  
4. pulley from pump

Twist hose to break bonding on pipe  
3 off. See **TORQUE WRENCH SETTINGS**

**Models without air conditioning**

"  
"  
"  
"  
"  
"  
"

5. power steering pump support bracket  
bolts  
6. bolts securing power steering pump to  
water pump housing  
7. support bracket  
8. power steering pump from water pump  
housing  
9. bolts securing alternator support bracket  
10. bracket

3 off. See **TORQUE WRENCH SETTINGS**  
2 off. See **TORQUE WRENCH SETTINGS**  
Place aside  
2 off. See **TORQUE WRENCH SETTINGS**



# COOLING 2.0

## REPAIRS

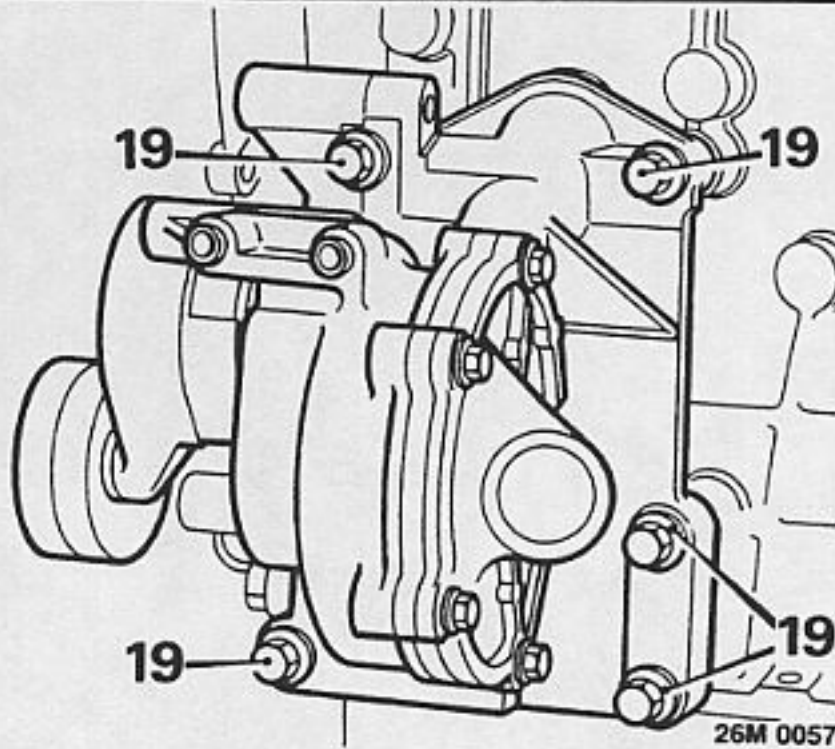
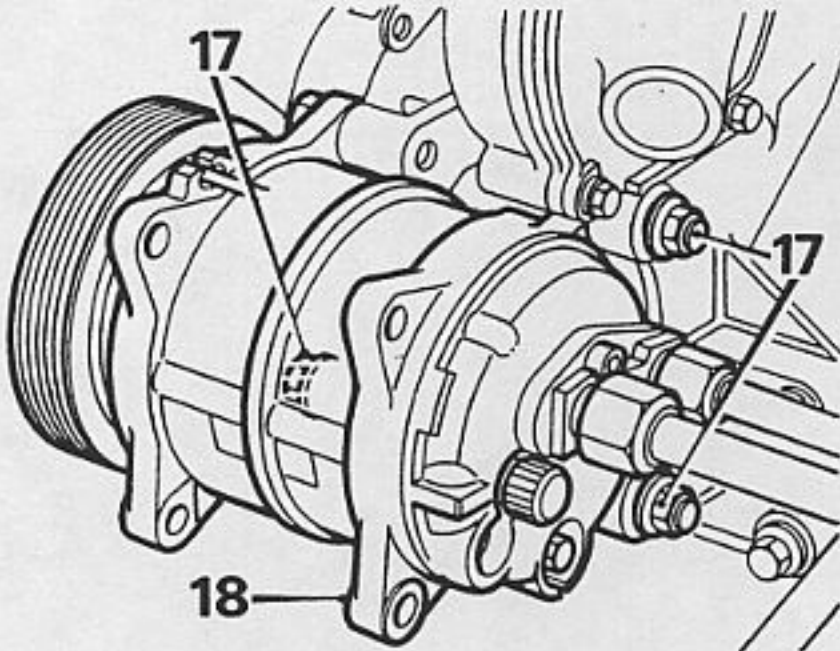
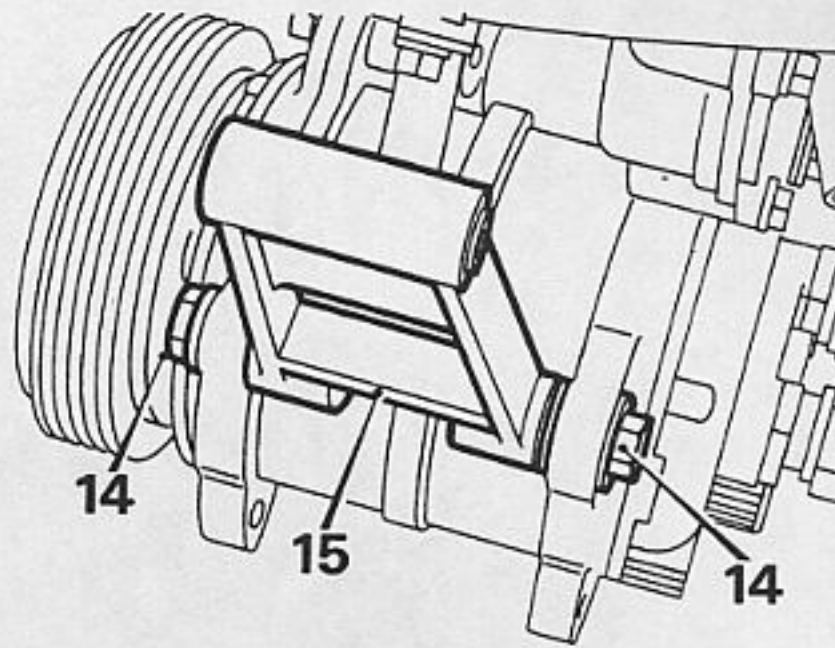
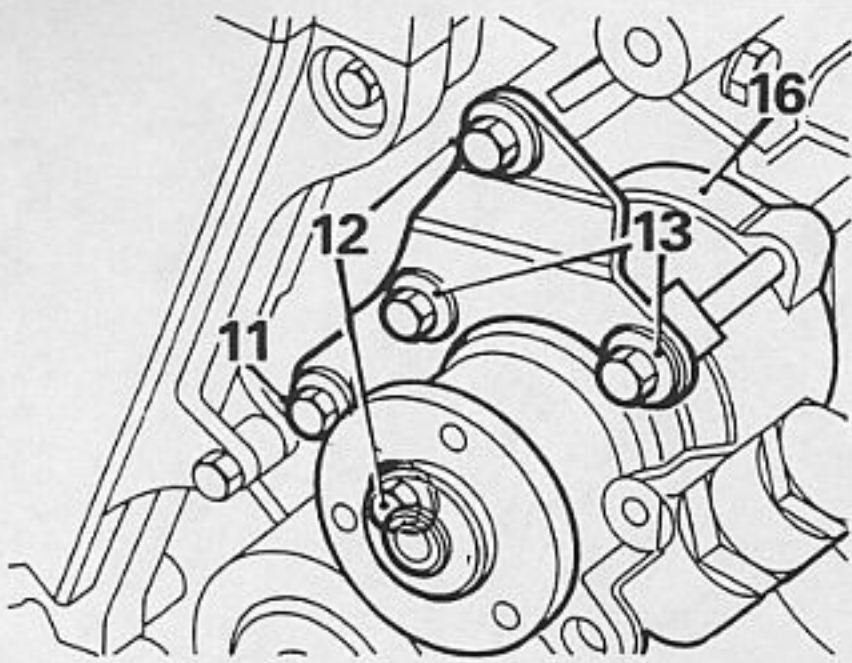

26M 0057

### Models with air conditioning

Slacken	11. power steering pump support bracket bolt	See <b>TORQUE WRENCH SETTINGS</b>
Remove	12. power steering pump support bracket bolts	2 off. See <b>TORQUE WRENCH SETTINGS</b>
"	13. bolts securing power steering pump to water pump housing	2 off. See <b>TORQUE WRENCH SETTINGS</b>
"	14. bolts and nuts securing alternator support bracket	2 off. See <b>TORQUE WRENCH SETTINGS</b>
Release	15. bracket from compressor	
Remove	16. power steering pump from water pump housing	Manoeuvre from behind bracket and place aside
"	17. bolts and nuts securing compressor to water pump housing	4 off. See <b>TORQUE WRENCH SETTINGS</b>
"	spacer washers from rear bolts	2 off
Release	18. compressor from pump housing	

### Models without air conditioning

Remove	19. bolts securing water pump housing to cylinder block	5 off See <b>TORQUE WRENCH SETTINGS</b>
--------	---------------------------------------------------------	-----------------------------------------

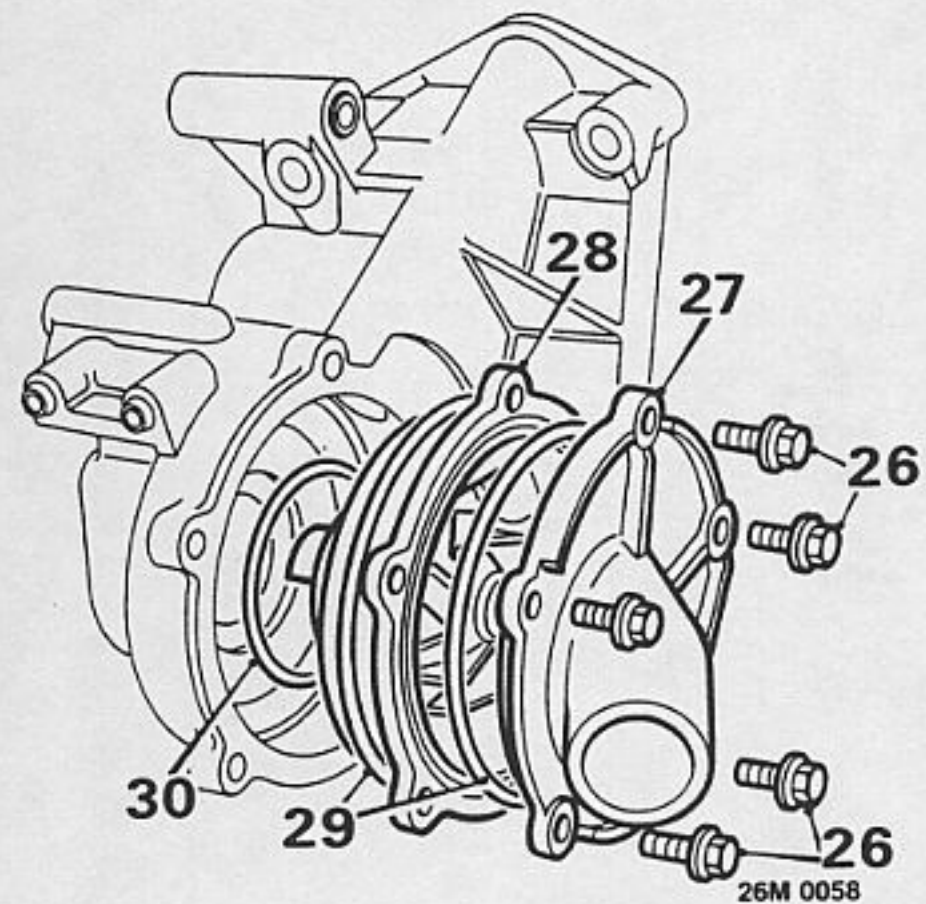
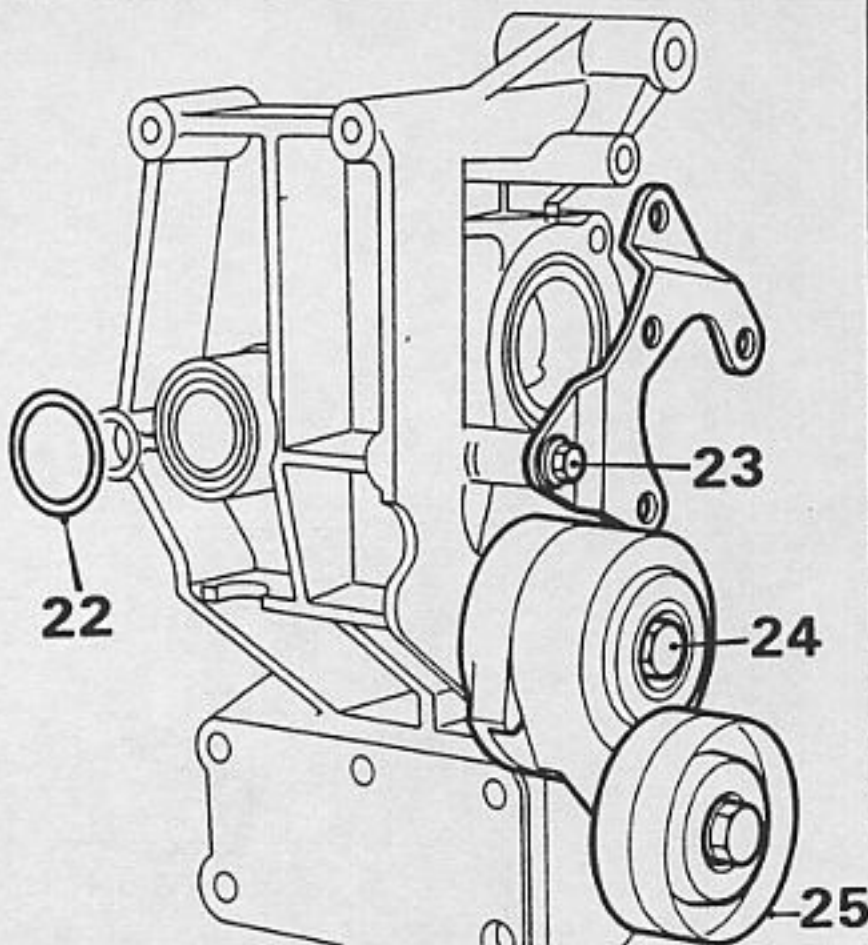
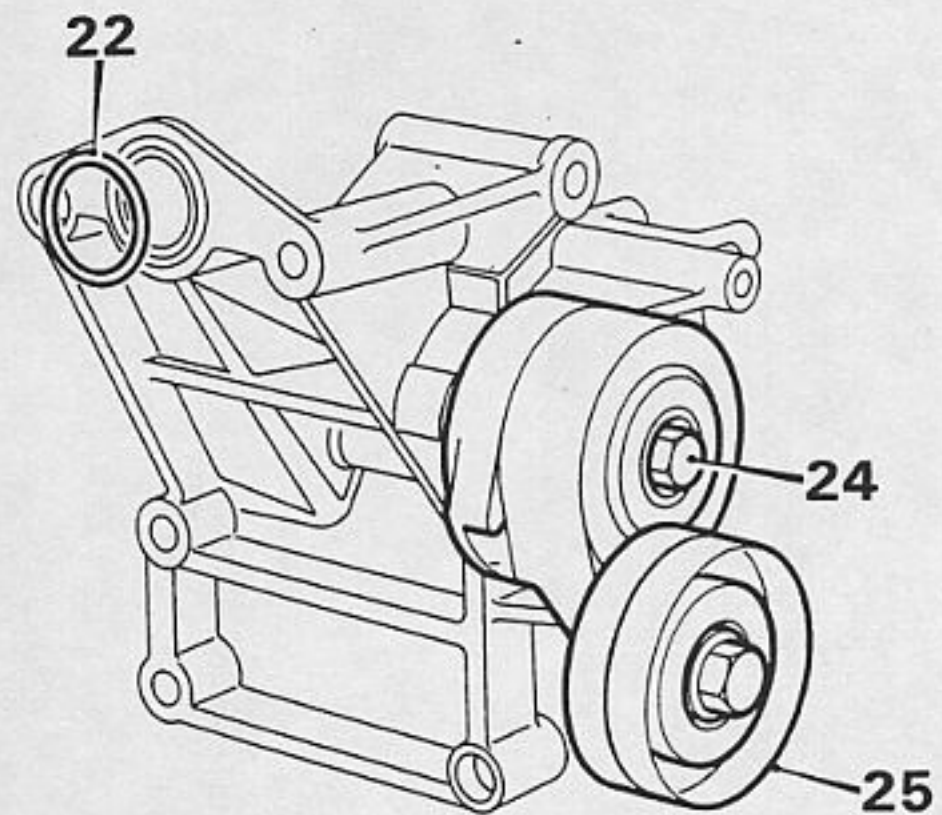
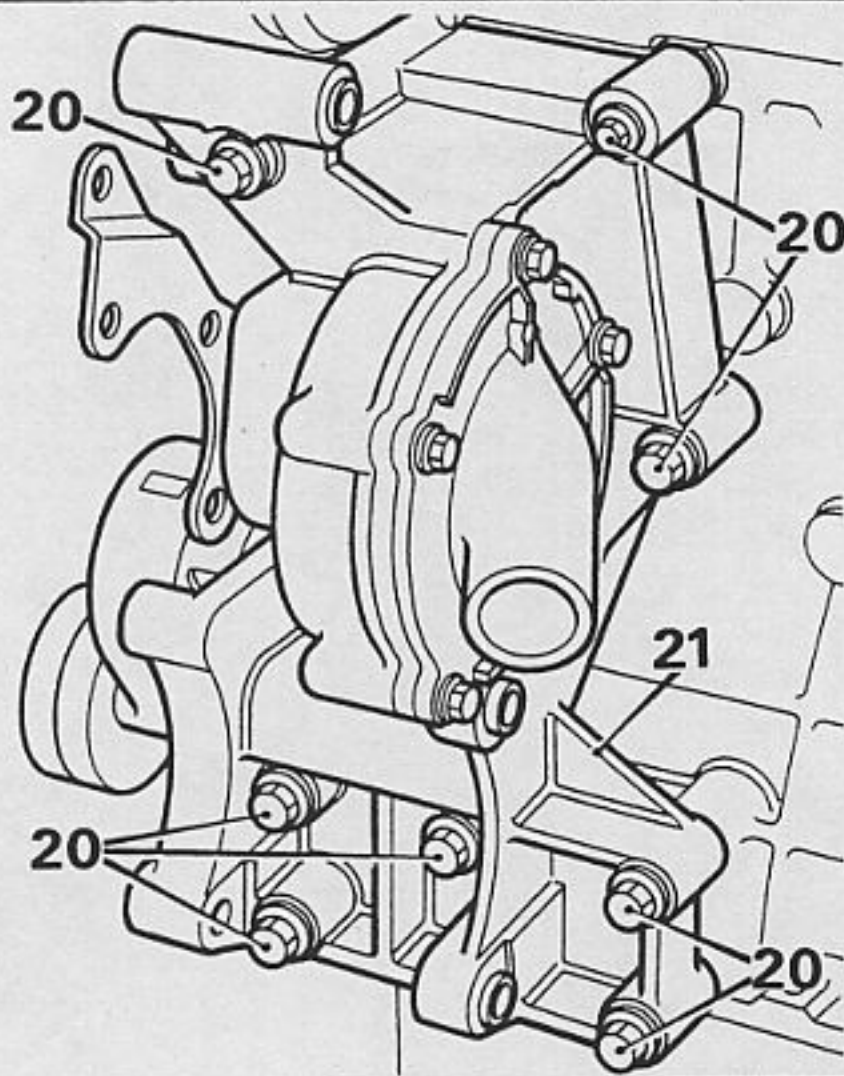

**Models with air conditioning**

**Remove** 20. bolts securing water pump housing to cylinder block 8 off See **TORQUE WRENCH SETTINGS**

**All models**

" 21. pump housing

**Discard** 22. sealing ring

**Clean** sealing ring groove

*Do not carry out further dismantling if component is removed for access only*

**Remove** 23. bolt securing power steering pump bracket

" 24. bolt securing tensioner assembly See **TORQUE WRENCH SETTINGS**

" 25. tensioner

" 26. bolts securing water pump housing cover 5 off. See **TORQUE WRENCH SETTINGS**

" 27. water pump housing cover

" 28. pump from housing

**Discard** 29. sealing rings 2 off

" 30. sealing ring

**Clean** sealing ring grooves

" bolts holes in cylinder block

**Apply** Loctite 405 to sealing ring grooves

**Transfer** serviceable components to new housing

**Reassemble** components In reverse order to dismantle



# COOLING 2.0

## REPAIRS

Adjust  
Refill

drive belt tension  
cooling system

See **ELECTRICAL**  
see **Adjustments**



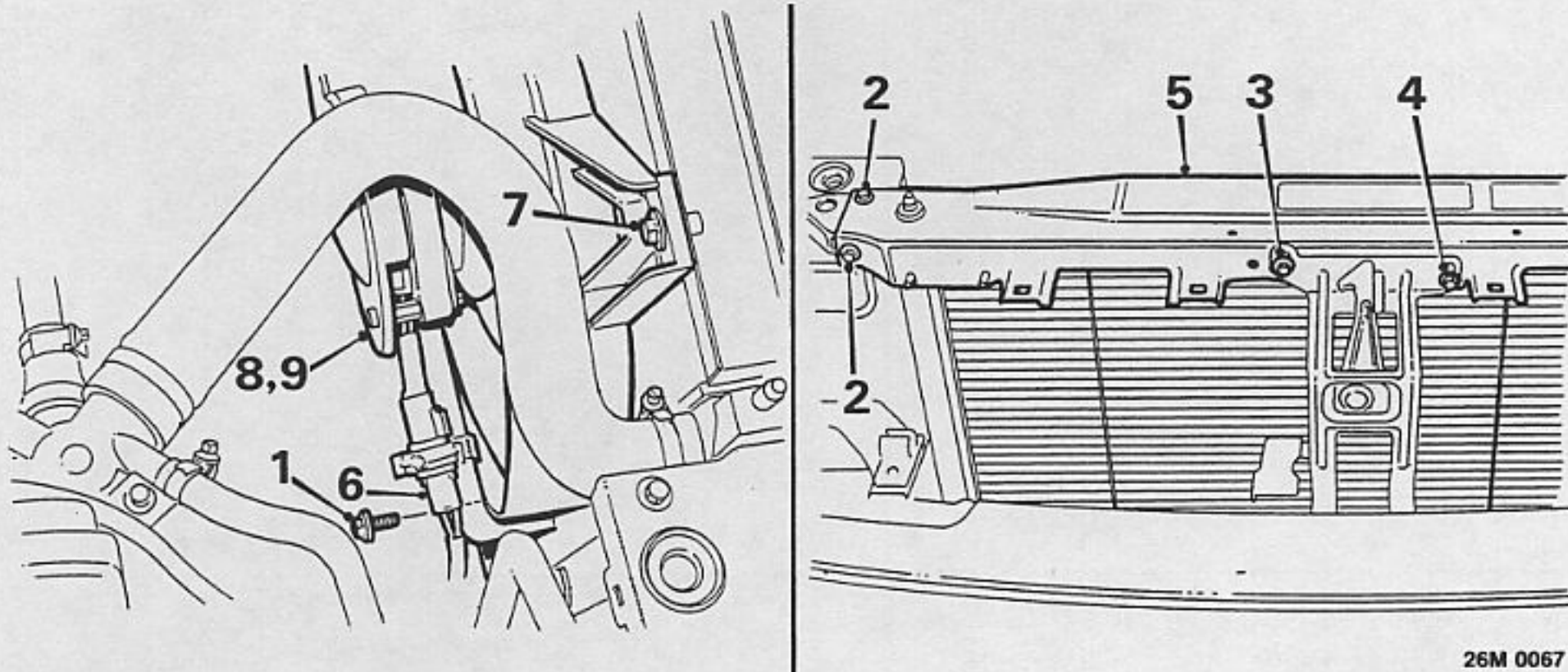

**COOLING FAN ASSEMBLY - TURBO**

Action	Ref. Detail	Special Instructions
Raise	front of vehicle	
Remove	bolts from front under belly panel	<b>WARNING: Support on safety stands</b>
"	front under belly panel from body	6 off. See <b>TORQUE WRENCH SETTINGS</b>
"	1. lower bolts from fan assembly	2 off. See <b>TORQUE WRENCH SETTINGS</b>
"	2. bolts from centre platform	4 off. See <b>TORQUE WRENCH SETTINGS</b>
"	3. screw from safety catch	<b>Note: Earth cable</b>
"	4. nut from safety catch	See <b>TORQUE WRENCH SETTINGS</b>
"	straps from bonnet release cable	See <b>TORQUE WRENCH SETTINGS</b>
"	5. bonnet platform from body	2 off, position cable in channel
Disconnect	6. multiplug from fan motor	Ensure grommets correctly engaged
Remove	7. upper bolts from fan assembly	2 off. See <b>TORQUE WRENCH SETTINGS</b>
Release	8. fan assembly	
Remove	9. fan assembly	<b>CAUTION: Fan, motor and cowl are balanced assembly, do not dismantle</b>
Clean	components	
Reassemble	components	In reverse order to dismantle



# COOLING 2.0

## REPAIRS

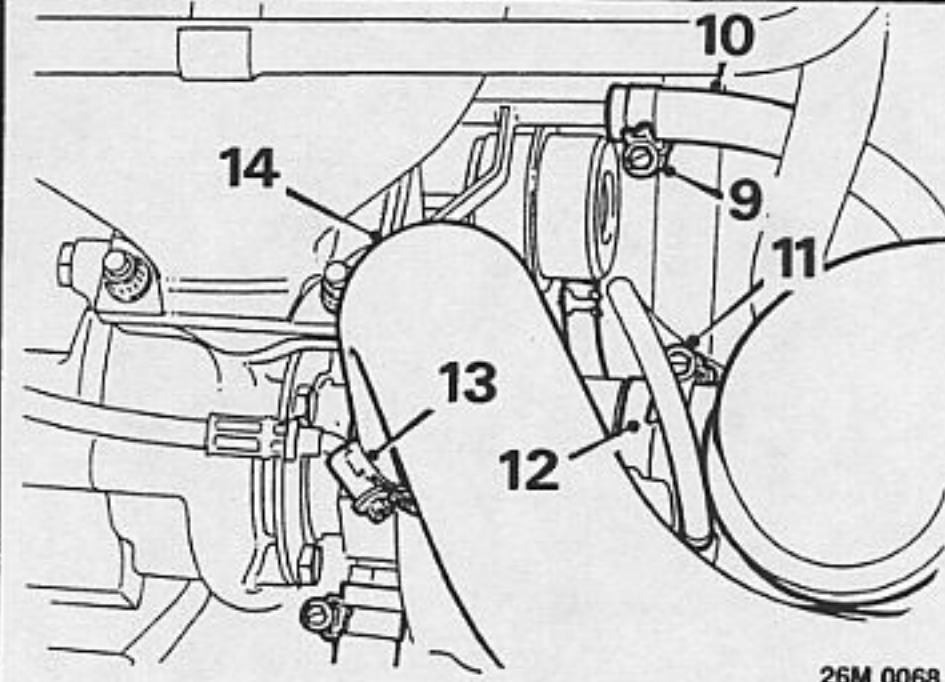
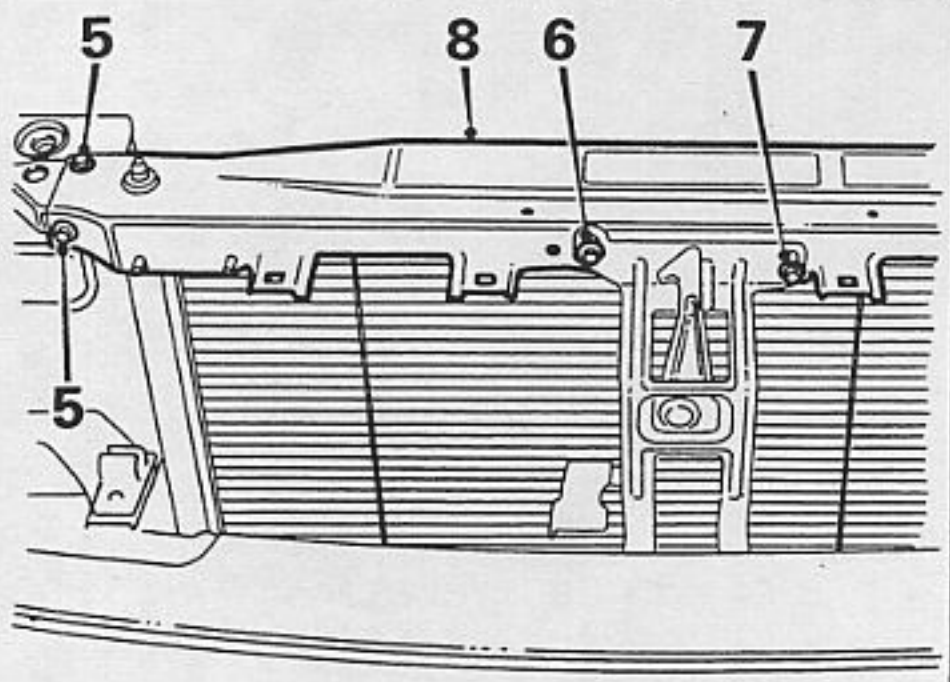
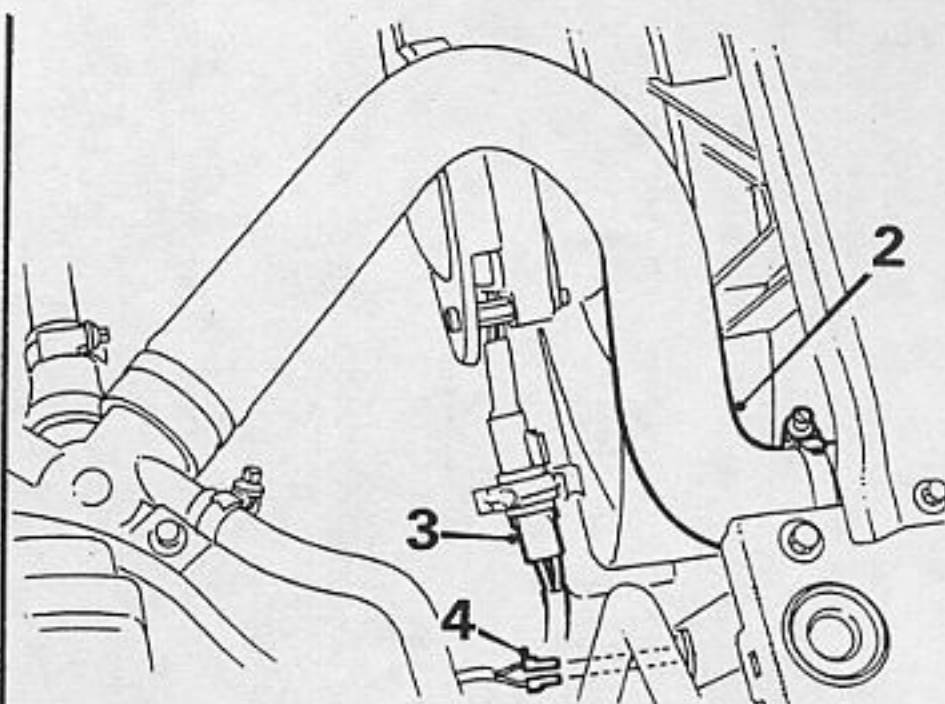
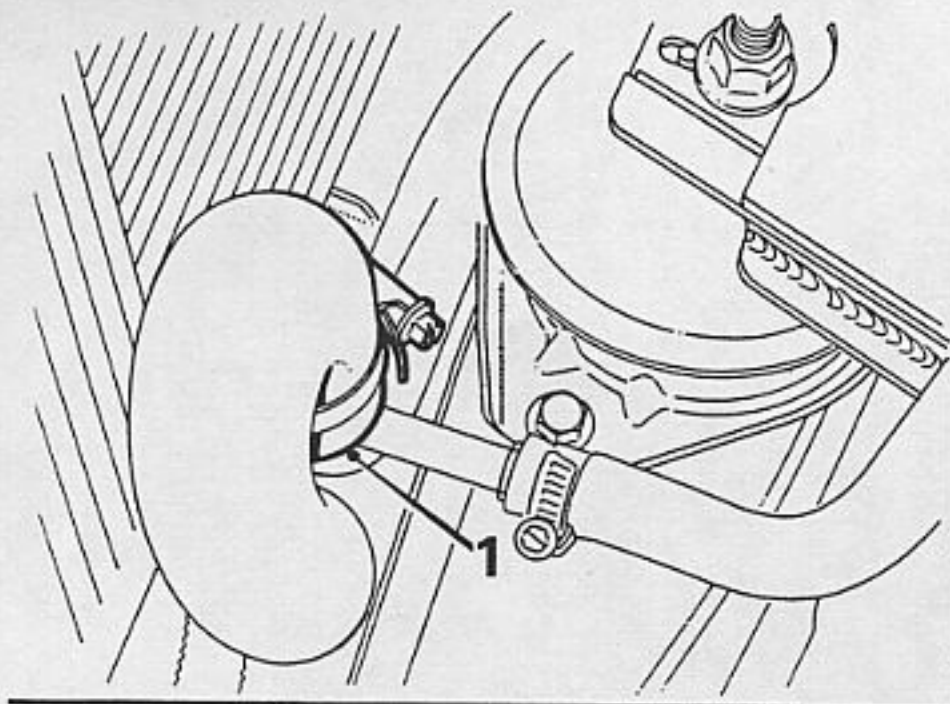

26M 0068

### RADIATOR AND INTERCOOLER - TURBO

Action	Ref. Detail	Special Instructions
Remove	filler cap from reservoir	<b>WARNING: System hot, protect hands against steam or boiling water, remove filler cap slowly to gradually release pressure</b>
"	R.H. head lamp	See <b>ELECTRICAL</b>
"	air cleaner assembly	See <b>MODULAR ENGINE MANAGEMENT SYSTEM</b>
Position	drain tray	Below radiator
Disconnect	1. bottom hose from radiator rail	Twist hoses to break bonding on pipe <b>CAUTION: Using a lever can deform the pipe or end tank</b> <b>WARNING: System hot, protect hands against steam or boiling water</b>
"	2. top hose from radiator	
"	3. multiplug from fan motor	
"	4. connectors from thermostatic switch	2 off
Remove	straps from bonnet release cable	2 off position cable in channel
"	5. bolts from centre platform	4 off. See <b>TORQUE WRENCH SETTINGS</b> <b>Note: Earth cable</b>
"	6. screw from safety catch	See <b>TORQUE WRENCH SETTINGS</b>
"	7. nut from safety catch	See <b>TORQUE WRENCH SETTINGS</b>
"	8. centre platform from body	Ensure grommets correctly engaged
Slacken	9. clip from turbocharger coolant outlet hose	
Remove	10. hose from turbocharger	
Slacken	11. clip from turbocharger intake hose	
Remove	12. hose from turbocharger	
Slacken	13. clip, turbocharger outlet to intercooler inlet hose	
Remove	14. hose	

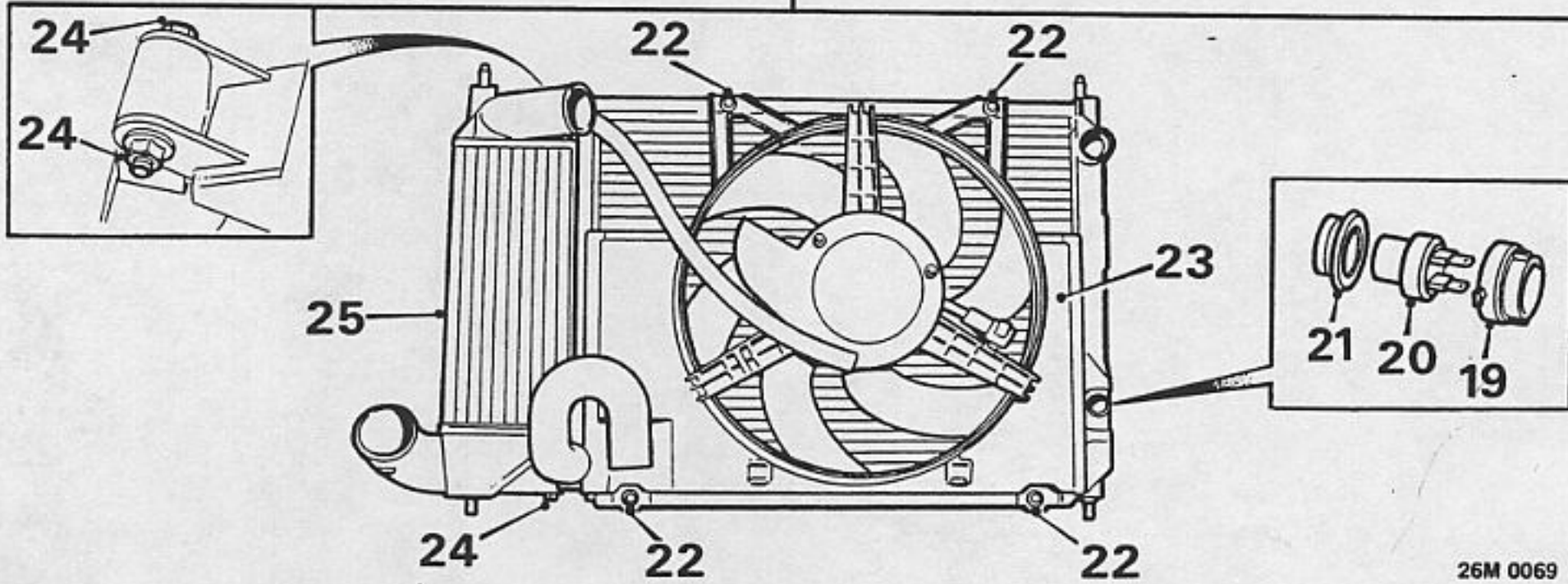
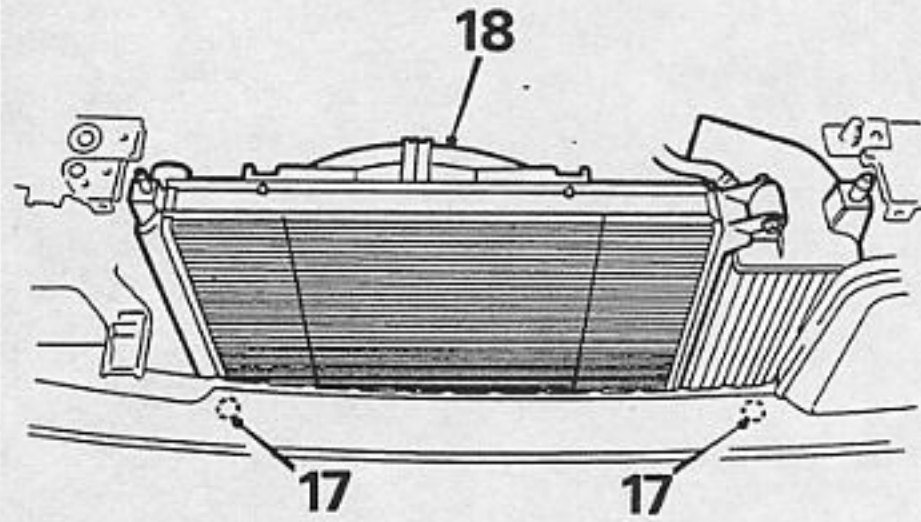
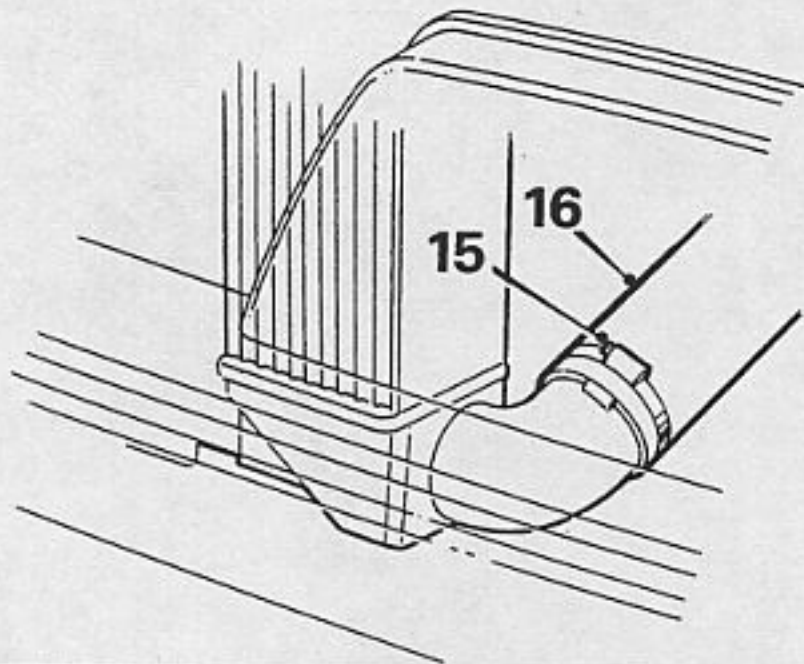
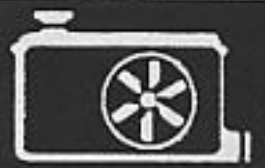

26M 0069

Slacken  
Remove  
Release  
Remove  
"  
"  
"  
"  
"  
"  
"  
"

- 15. clip from intercooler outlet hose
- 16. hose
- 17. radiator and intercooler from grommets
- 18. radiator and intercooler
- 19. retaining ring from thermostatic switch
- 20. thermostatic switch from seal
- 21. thermostatic seal from radiator
- 22. bolts from cooling fan assembly
- 23. cooling fan assembly
- 24. nut and bolts from intercooler
- 25. intercooler

Ensure grommets correctly engaged

4 off.

**CAUTION:** Fan, motor and cowl are balanced assembly do not dismantle  
3 off. See **TORQUE WRENCH SETTINGS**

Clean  
Renew  
Reassemble  
Refill

- components
- grommets
- components
- cooling system

If damaged or deteriorated

See **Adjustments**